

Component numbers are not the same as for original 1954 Leak schematic.

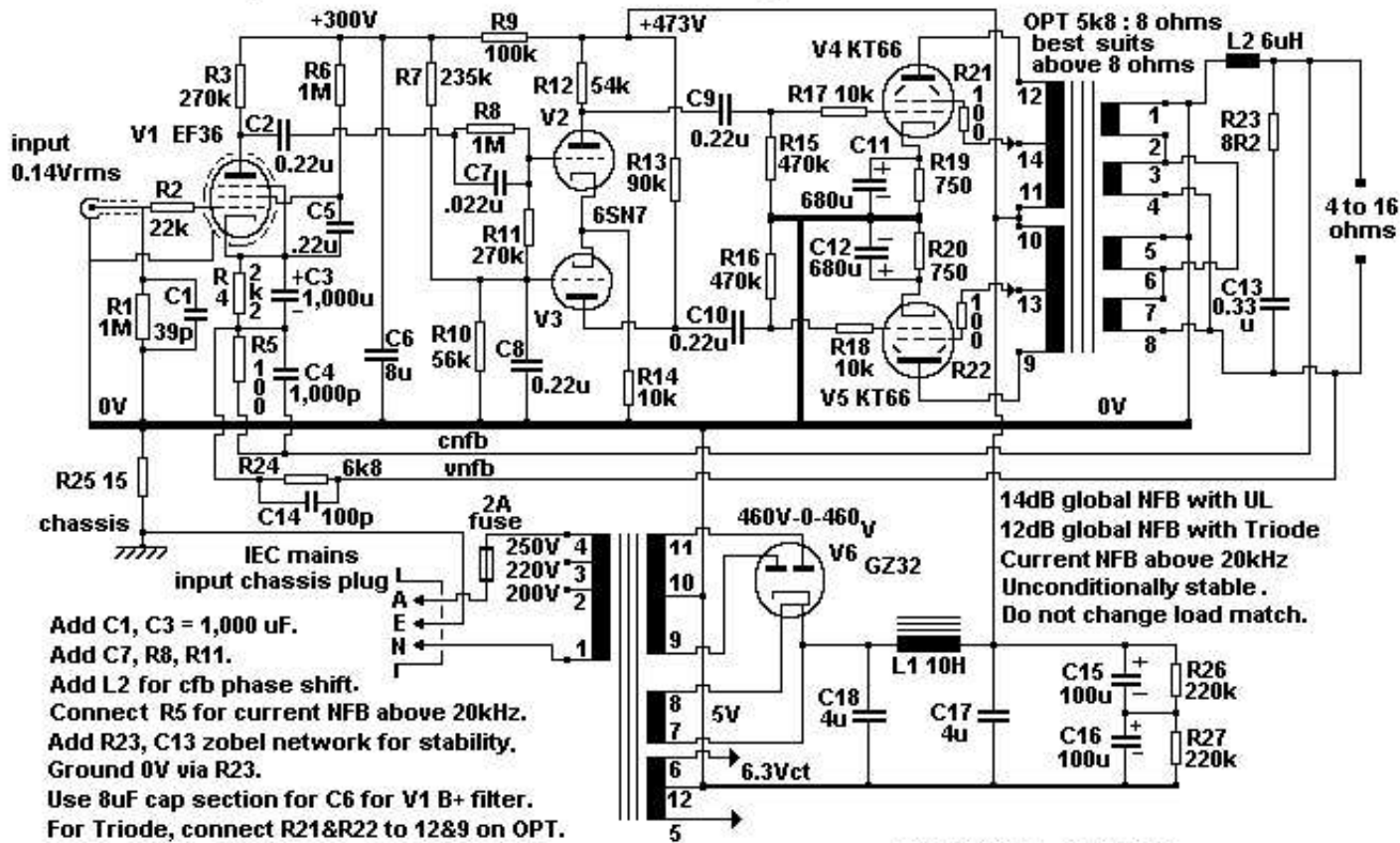

- Add C1, C3 = 1,000 uF.
- Add C7, R8, R11.
- Add L2 for cfb phase shift.
- Connect R5 for current NFB above 20kHz.
- Add R23, C13 zobel network for stability.
- Ground 0V via R23.
- Use 8uF cap section for C6 for V1 B+ filter.
- For Triode, connect R21&R22 to 12&9 on OPT.
- Revise biasing V2&V3 with R7, R10, C8, R14.
- R3 changed to 270k.

LEAK TL12, UL or TRIODE

Revised march 2005 turneraudio.com.au april 2006